



Product designation
Product type designation
Type

Automatic battery chargers
BCG
Single phase automatic battery charger 1 charging level for sealed and non-sealed lead-acid batteries

Power supply

Rated voltage Us

min	VAC	110
Max	VAC	240 ±10%

Operational frequency

min	Hz	50 ±10%
max	Hz	60 ±10%

Power consumption

Max	VA	230
Max	W	97
	A	4

Internal fuse

Charging cycle

Reference standards

IEC62368-1

Battery type

non-sealed and sealed lead-acid batteries

Battery voltage

VDC 12

Charging voltage (Uc)

in pos. V1:13.8; V2:13.5

Boost

% Uc +4.4

Charging current (Ic)

A 6

Charging current adjustment

% Ic 20 to 100

Protections

Main supply fuse; charging inhibition due to:
1. Short circuit at battery terminals;
2. Reverse battery polarity; 3. Low voltage at battery poles; 4. Output overload.

Indications

LED indicator for operating status

Yes

LED reverse battery polarity

Yes

Alarm output circuit

Output type

1 relay

Rated capacity	5A 30VDC		
Mechanical features			
Housing type	Internal panel mounting		
Terminals type	Fixed		
Fixing	35mm DIN rail or Screw fixing		
Weight	g	532	
Ambient conditions			
Temperature			
Operating temperature			
	min	°C	-30
	max	°C	+55
Storage temperature			
	min	°C	-30
	max	°C	+80
Protection degree	IP20		

Dimensions [mm (in)]

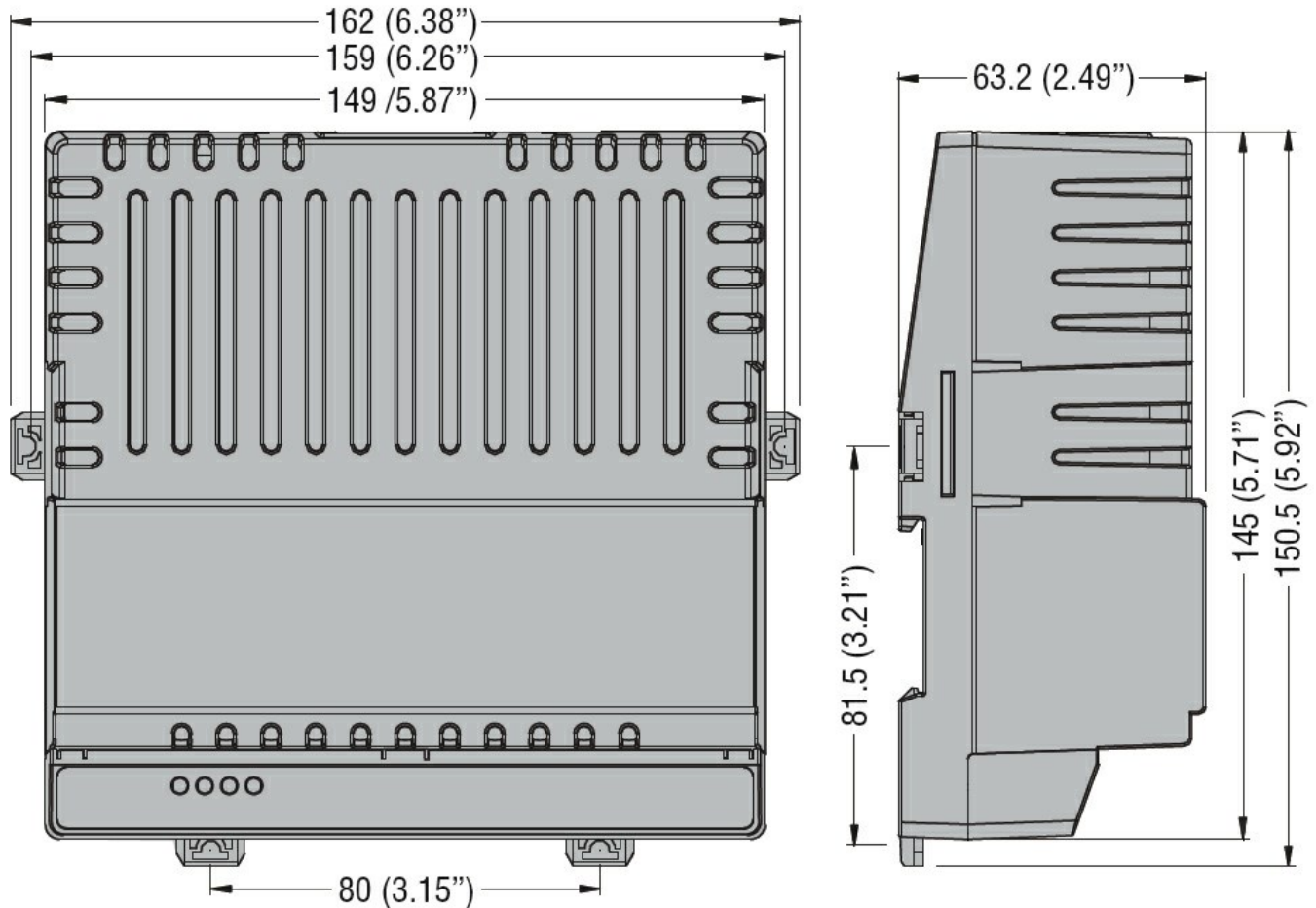

Wiring diagrams

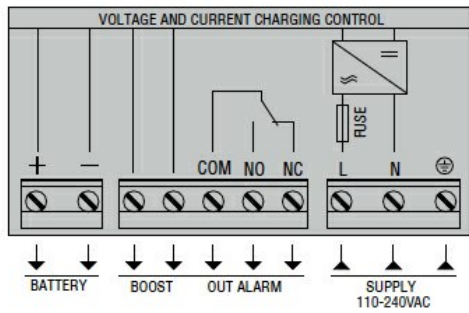

Certifications and compliance

Compliance

CSA C22.2 n°60950-1

IEC/EN/BS 61000-6-2

IEC/EN/BS 61000-6-3

IEC/EN/BS 62368-1

UL 60950-1

Certificates

cURus

EAC

ETIM classification

ETIM 8.0

EC000359 -
Universal charger